

CREATING A CLEANER, SAFER, HEALTHIER WORLD.



# S30

## MID-SIZE RIDE-ON SWEEPER

- Provide excellent indoor and outdoor dust control with the SweepMax® Plus system
- Achieve consistent cleaning results in the toughest applications
- Deliver easy operation and maintenance while running at peak performance

EQUIPMENT

# ACHIEVE EXCELLENT INDOOR AND OUTDOOR DUST CONTROL WITH THE **SWEEPMAX® PLUS CYCLONIC SYSTEM**



## REDUCE YOUR COST TO CLEAN

Increase productivity with the patented SweepMax® Plus cyclonic dry dust control system that reduces dust from reaching the filter, resulting in fewer shake backs and more time spent sweeping. Easy to set, colour coded brush wear indicator also ensures consistent sweeping.

## INCREASED HEALTH AND SAFETY

Reduce slip and fall potential by keeping floors clean of dust and debris with excellent dust control and debris pick-up. Achieve effective one-pass sweeping with a retractable, spring loaded re-circulation flap near the rear skirt, which re-circulates any debris that may escape over the main brush.

## EASY OPERATION AND MAINTENANCE

Deliver consistent sweeping results with the easy to operate and maintain S30, which runs at peak performance year after year. The optional 1-Step™ Start Button simplifies operator training with controls that enable sweeping systems to be activated with a single green button.

INSIDE THE

# S30

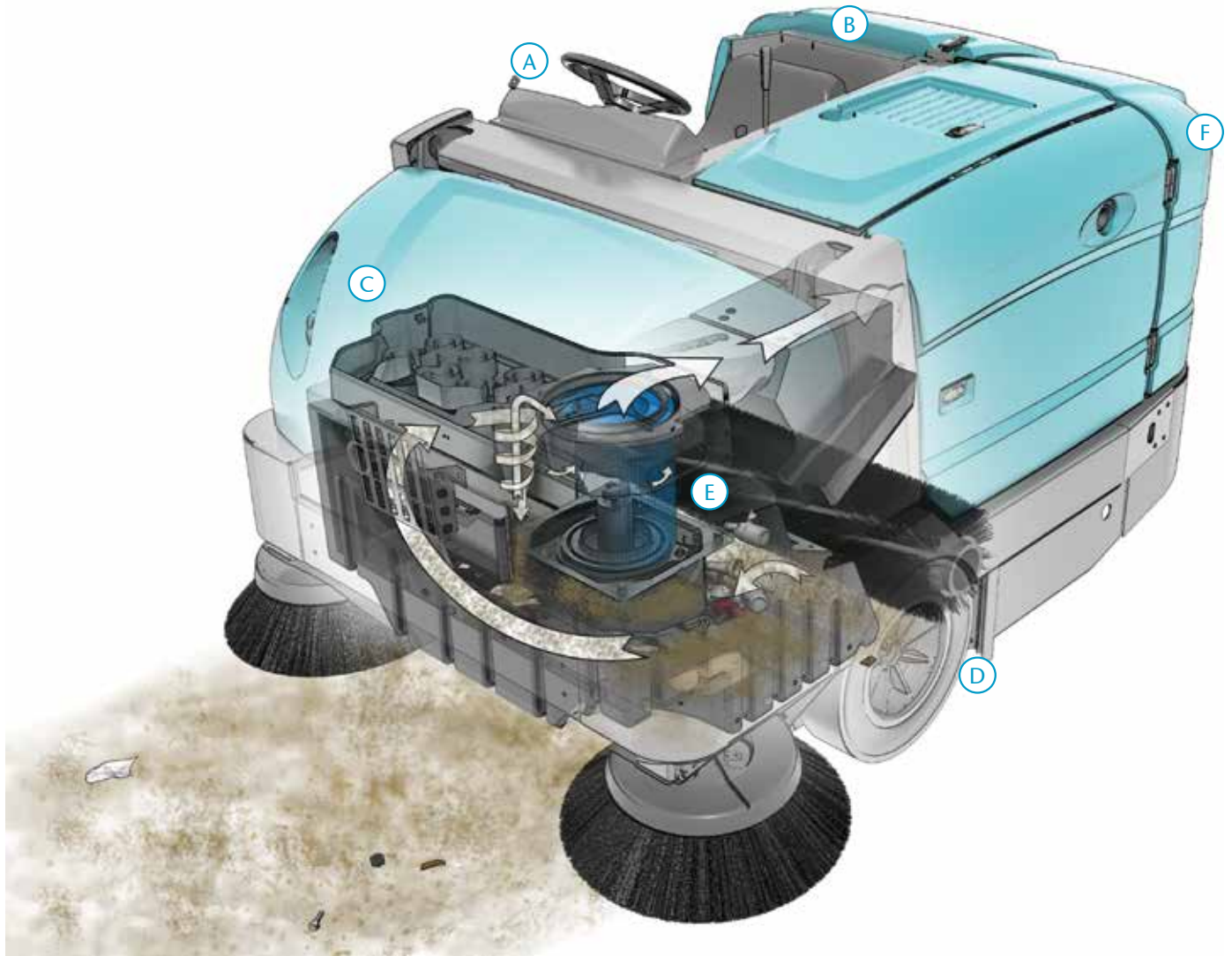

**A** **Easy to use.** Simple “All Levers Forward” control system delivers consistent sweeping performance and simplifies operation.

**B** **Cab forward design.** Exclusive cab forward design for reduced operator fatigue and increased comfort.

**C** **Thermo-Sentry™.** Ensure operator safety with Thermo-Sentry™ which monitors the hopper temperature and in dangerously high temperatures, initiates vacuum shutdown.

**D** **Spring loaded skirt.** Retractable, spring-loaded flap re-circulates debris for improved sweeping results.

**E** **3-stage filtration.** SweepMax® Plus provides cyclonic filtration and superior dry dust control on all floor types.

**F** **Rounded corners.** Rounded corner design improves turn-off from walls or racking to minimise potential damage.



# ENGINEERED TO BE EASY TO OPERATE AND MAINTAIN



PRESSURISED CABIN

Operate safely and comfortably in the most severe environments with an optional FOPS Certified (ISO 3449) pressurised cabin, available with air conditioning.



X4 CONFIGURATION

Travel between work sites safely and quickly with the S30 X4 configuration that travels up to 24 km/h on a stable 4 wheel platform with comfortable suspension.



DUAL SIDE BRUSHES

Achieve outstanding results in diverse environments with dual side brushes which allows you to sweep a path of 2,032 mm in a single pass.



NO-TOOL BRUSH CHANGE

Reduce downtime and operator fatigue with easy no-tool, brush removal and change, aided by the self-guiding 8-spline drive and idler hub.

## S30 MID-SIZE RIDE-ON SWEEPER

### SWEEPING SYSTEM

Cleaning path	
with single side brush	1,588 mm
with dual side brush	2,032 mm

### BRUSH DRIVE SYSTEM

Main brush	
Main brush length	1,145 mm
Main brush lift	Mechanical or hydraulic
Main brush change	No-tool
Side brush diameter	660 mm
Debris hopper	
Volume capacity	395 L
Weight capacity (polyethylene)	490 kg
Weight capacity (steel)	545 kg
Dump height (variable to)	1,525 mm
Dump reach	760 mm

### PROPELLING SYSTEM

Propel speed forward (variable to)	
3-wheel (petrol/LPG)	13 km/h
X4 (diesel)	24 km/h
Engine (petrol/LPG)	37.2 kW
Engine (diesel)	19 kW
Gradeability	
Full hopper (petrol/LPG)	10° / 18%
Full hopper (diesel)	6° / 10.5%
Empty hopper (petrol/LPG)	14° / 25%
Empty hopper (diesel)	9° / 16%
Ground clearance	100 mm

### DUST CONTROL SYSTEM

Filter system	3-stage
Stage 1	Perma-filter™
Stage 2	SweepMax® Plus Cyclonic pre-filter
Stage 3	Donaldson Ultra-Web® Nanofiber canister filter
Filter area	7.4 m <sup>2</sup>
Dust filtration (up to)	0.5 microns @ 99% efficiency
Shaker mechanism	ShakeMax® 360 Orbital Shaker
Vacuum fan speed	
Normal sweeping mode	4,600 rpm
Litter sweeping mode	5,500 rpm
Vacuum diameter	280 mm

### MACHINE SPECIFICATIONS

Length	2,360 mm
Width	1,590 mm
Height	
With overhead guard	2,095 mm
Without overhead guard	1,475 mm
Weight (net, 3-wheel)	1,620 kg
Minimum aisle turn	2,870 mm

### WARRANTY

See your local representative for warranty information.

\*Specifications subject to change without notice.