

## B 50 W BP PACK 115AH+D51

Compact B 50 W Bp push scrubber dryer for wet floor cleaning with robust and durable aluminium components, D 51 single-disc brush head and powerful 115 Ah AGM battery.



Made in Europe



Order no.

1.533-238.0

### Technical data

EAN code		4054278871325
Drive type		Battery
Traction drive		Traction motor
Working width of brushes	mm	510
Working width, vacuuming	mm	850
Tank of fresh/dirty water	l	50 / 50
Theoretical area performance	m <sup>2</sup> /h	max. 3060
Practical area performance	m <sup>2</sup> /h	1840
Battery type		maintenance-free
Battery	V / Ah	24 / 115
Battery runtime	h	max. 3
Battery charging time	h	approx. 10
Power supply for battery charger	V / Hz	100 - 240 / 50 - 60
Driving speed	km/h	max. 6
Brush rotational speed	rpm	140
Brush contact pressure	kg / g/cm <sup>2</sup>	29 / 32
Aisle turning width	mm	1400
Water consumption	l/min	max. 2.5
Sound pressure level	dB(A)	65
Total permissible weight	kg	245
Weight without accessories	kg	189
Dimensions (L × W × H)	mm	1367 × 609 × 1082

### Equipment

Disc brush	■
Powerful traction drive	■
Battery	■
Battery charger	■
Squeegee, curved	■
2-tank system	■
robust aluminium die-cast suction bar	■
Motor	Battery
operation using app	■
Type of suction lips	Linatex®
Kärcher colour and operating concept	■
Kärcher Intelligent Key System (KIK) with over 30 user languages and individual user rights	■
Home Base fastening possibilities for mop or similar	■
Easy Operation selector switch	■

■ Included in the scope of supply.

Users must receive training on this device.



### Extremely compact machine

- Good overview and excellent manoeuvrability.
- Easy handling, safe and robust to prevent damage.



### Connectivity/"Machine connect" smartphone app

- Expanded range of functions and information.
- Resource monitoring, increase in productivity, informative animations for maintenance and troubleshooting.
- Adjustment of parameters, editing of KIK authorisations.

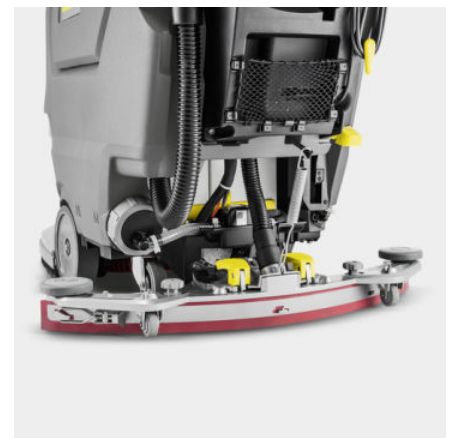

### Brush head and squeegee made from cast aluminium

- Robust and hard-wearing components.
- Fewer machine downtimes and higher productivity at lower costs.

## ACCESSORIES FOR B 50 W BP PACK 115AH+D51



	Order no.	Description	
<b>DISC BRUSHES</b>			
Disc brush, medium, red, 510 mm	1 4.905-026.0	Red standard disc brush for regular maintenance cleaning.	■
Disc brush complete white D51, very soft, White, 510 mm	2 4.905-028.0	White, soft disc brush for the gentle cleaning of sensitive floor coverings.	□
Disc brush, soft, natural, 510 mm	3 4.905-027.0	Natural-coloured, soft disc brush for cleaning and polishing textured floor coverings.	□
Disc brush complete black D51, hard, Black, 510 mm	4 4.905-029.0	Black, very abrasive disc brush for the deep cleaning of hard-wearing floor coverings with very sticky dirt.	□
<b>BRUSH HEADS</b>			
Brush head D51	5 2.763-051.0	Robust and compact D 51 aluminium brush head with a disc brush and working width of 51 cm. Integrated deflector roller, low operating nose and colour-coded components.	■
<b>SQUEEGEES AND SQUEEGEE BLADES</b>			
<b>Squeegees</b>			
Squeegee, 850 mm, parabolic	6 4.778-008.0	For excellent suction and drying results: robust, parabolic aluminium squeegee with 850 mm suction width and quick coupling. Allows tool-free change of suction lips.	■
<b>Squeegee blades</b>			
Squeegee blades, Linatex®, 944 mm	7 4.400-011.0	Tear-proof Linatex® suction lip set for parabolic squeegees of 850 mm in width. With special inlet openings for optimum suction results on crevices and profiled floor coverings.	■
Squeegee blades, oil-resistant, slotted, 942 mm	8 4.400-005.0	Low-wear, oil-resistant suction lip made from polyurethane. Triple-coated material for high flexibility and optimal peel properties. For parabolic squeegee with 850 mm suction width.	□
<b>TRACTION BATTERIES AND CHARGERS</b>			
<b>Batteries</b>			
Battery kit, 24 V, 115 Ah, maintenance-free	9 2.815-091.0	Battery kit with 24 V voltage and 115 Ah (C5) capacity. Comprising several maintenance-free single AGM batteries.	■
<b>Accessories for batteries</b>			
Battery installation kit	10 2.638-229.0	Installation kit for installing a battery kit in a machine. Incl. two spacers and one connection cable. Image similar.	■
<b>Battery and charger kits</b>			
Li-ion battery installation kit	11 2.644-393.0	Conversion kit for installing a lithium-ion battery in the B 50 W scrubber dryer from Kärcher. The battery is not included in the scope of supply. Image similar.	□
<b>DISC PADS / PAD DRIVE BOARDS</b>			
<b>Microfibre pad</b>			
Microfibre pad, White, 508 mm, 5 x	12 6.371-271.0	Microfibre disc pad for the reliable and gentle removal of grey haze. Ideal for fine stoneware tiles.	□
<b>Pads</b>			
Pad, soft, White, 508 mm, 5 x	13 6.371-320.0	Soft, non-abrasive pad for polishing to a dazzling shine.	□
Pad, soft, beige, 508 mm, 5 x	14 6.369-468.0	Beige-coloured pad for ultra high-speed polishing and cleaning.	□

■ Included in the scope of supply. □ Available accessories.

## CONTACT US

The Experts in Cleaning Equipment



+61 9249 8744  
 ccequipment.com.au  
 info@ccequipment.com.au  
 4 STANFORD WAY, MALAGA WESTERN AUSTRALIA 6090  
 PO BOX 2438 MALAGA WESTERN AUSTRALIA 6944  
 ABN: 53 780 286 266